

JANSER GmbH

JANVAC 1600-H POWER

Baureihe 2021

115 095 200

Janser GmbH
Böblinger Straße 91
D-71139 Ehningen

Telefon +49-(0)7034-1270

Fax +49-(0)7034-8838

info@janser.com
www.janser.com

Schleifstaubsauger JANVAC 1600-H POWER

Artikelnr.: 115 095 200

Seite 2 von 9 / 10-2021

06.04.2022/sai

A - Baugruppen

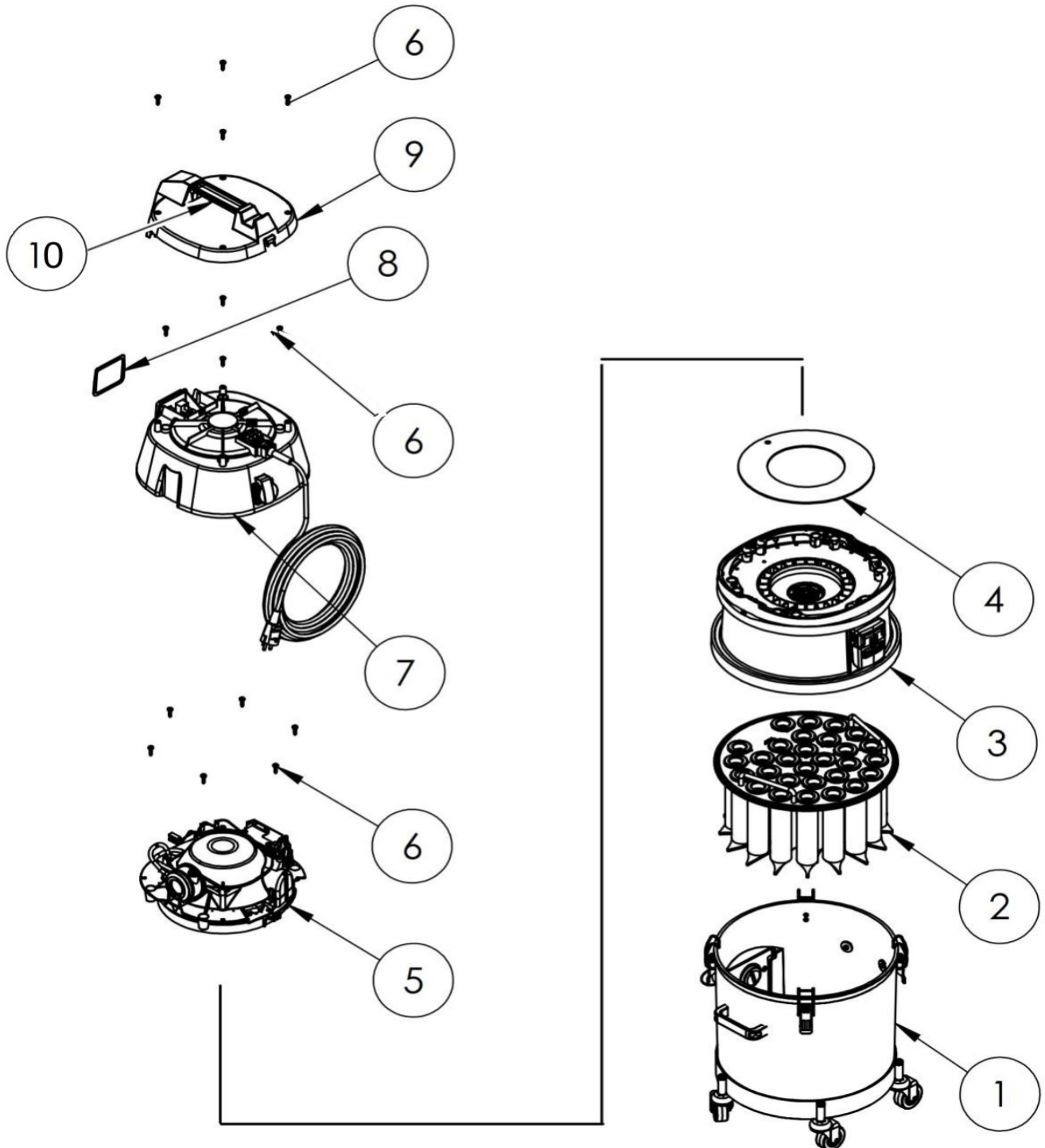

B - Motorkopf

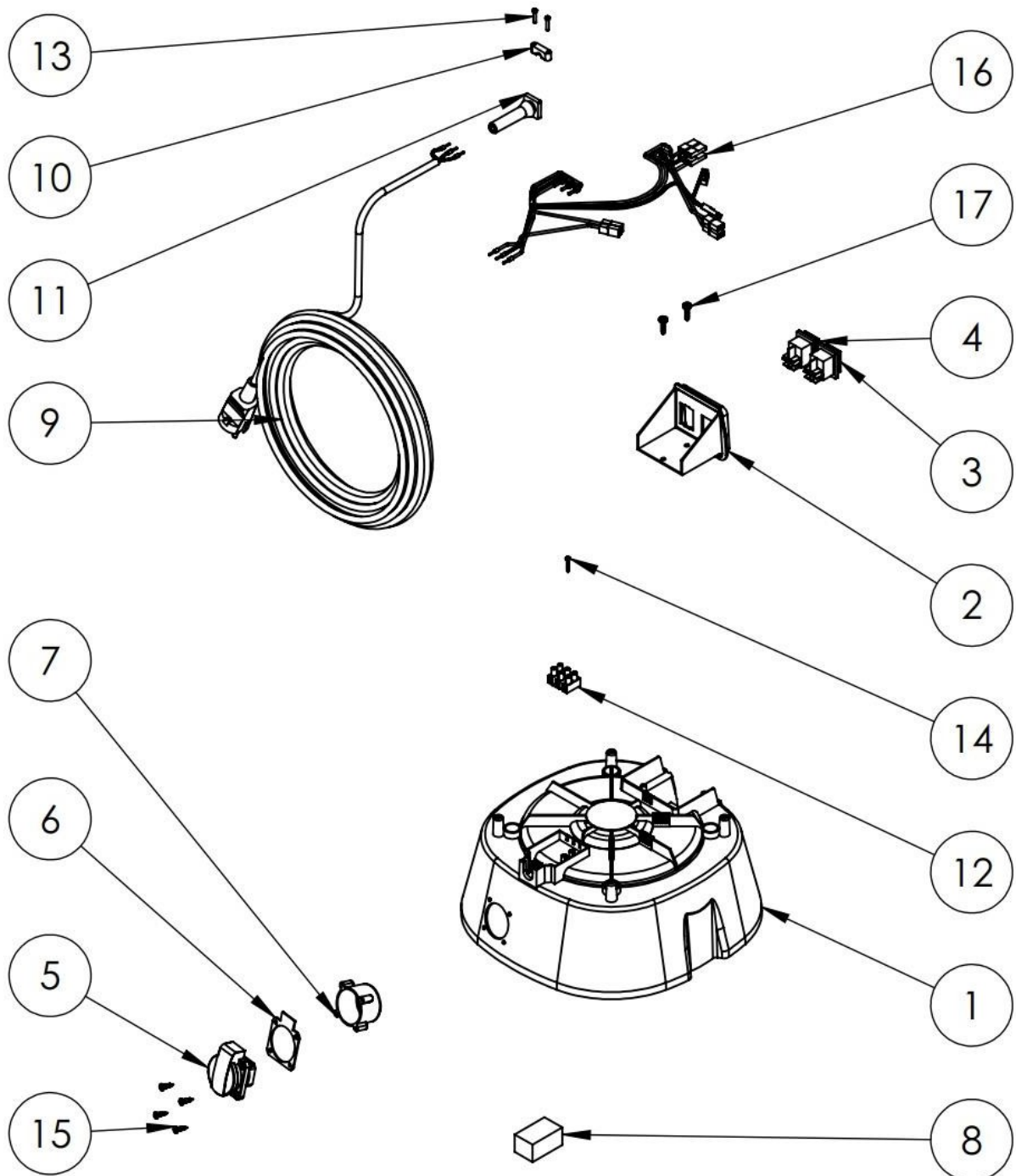

C – Pumpeneinheit

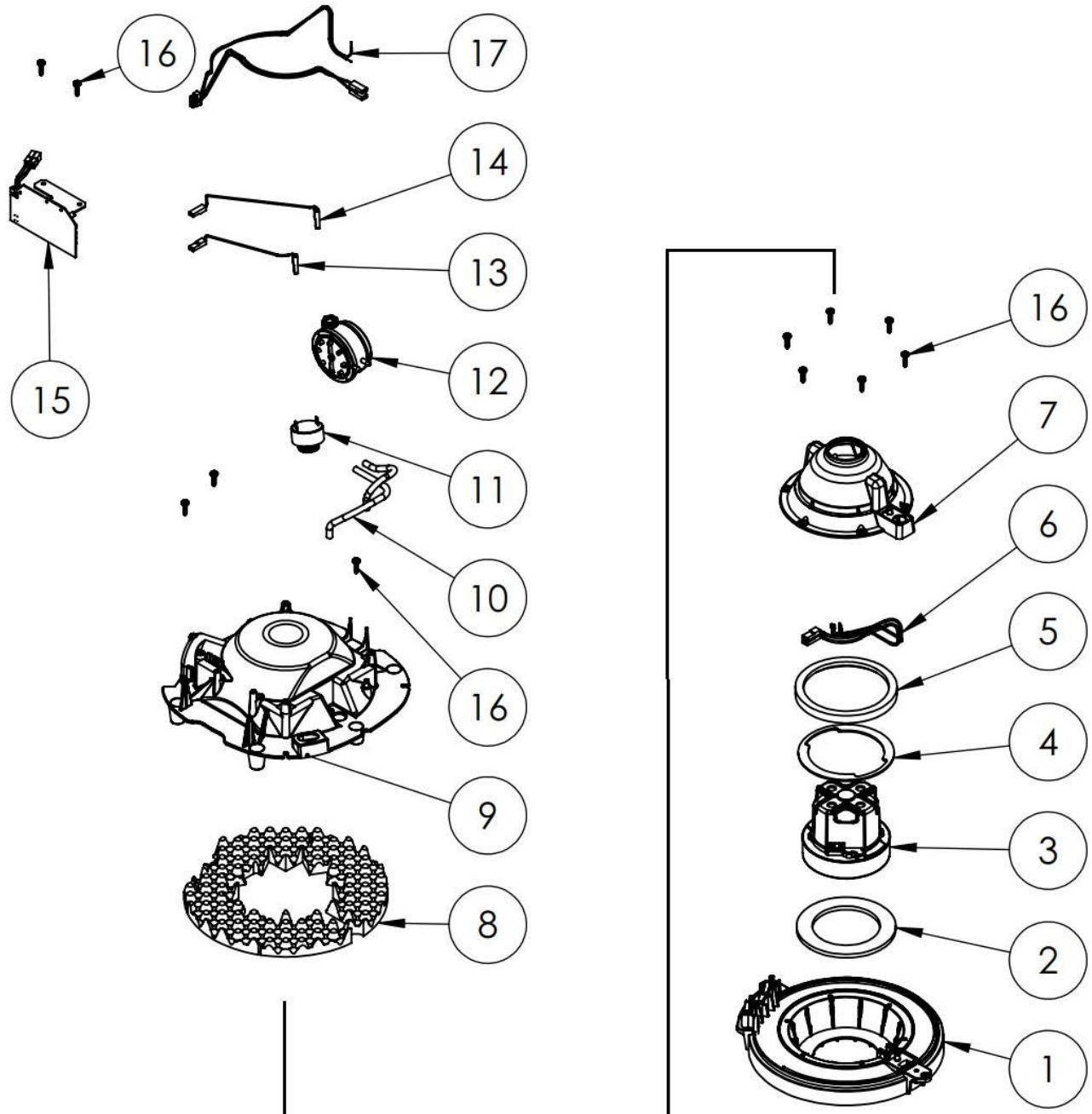

D - Adapterring

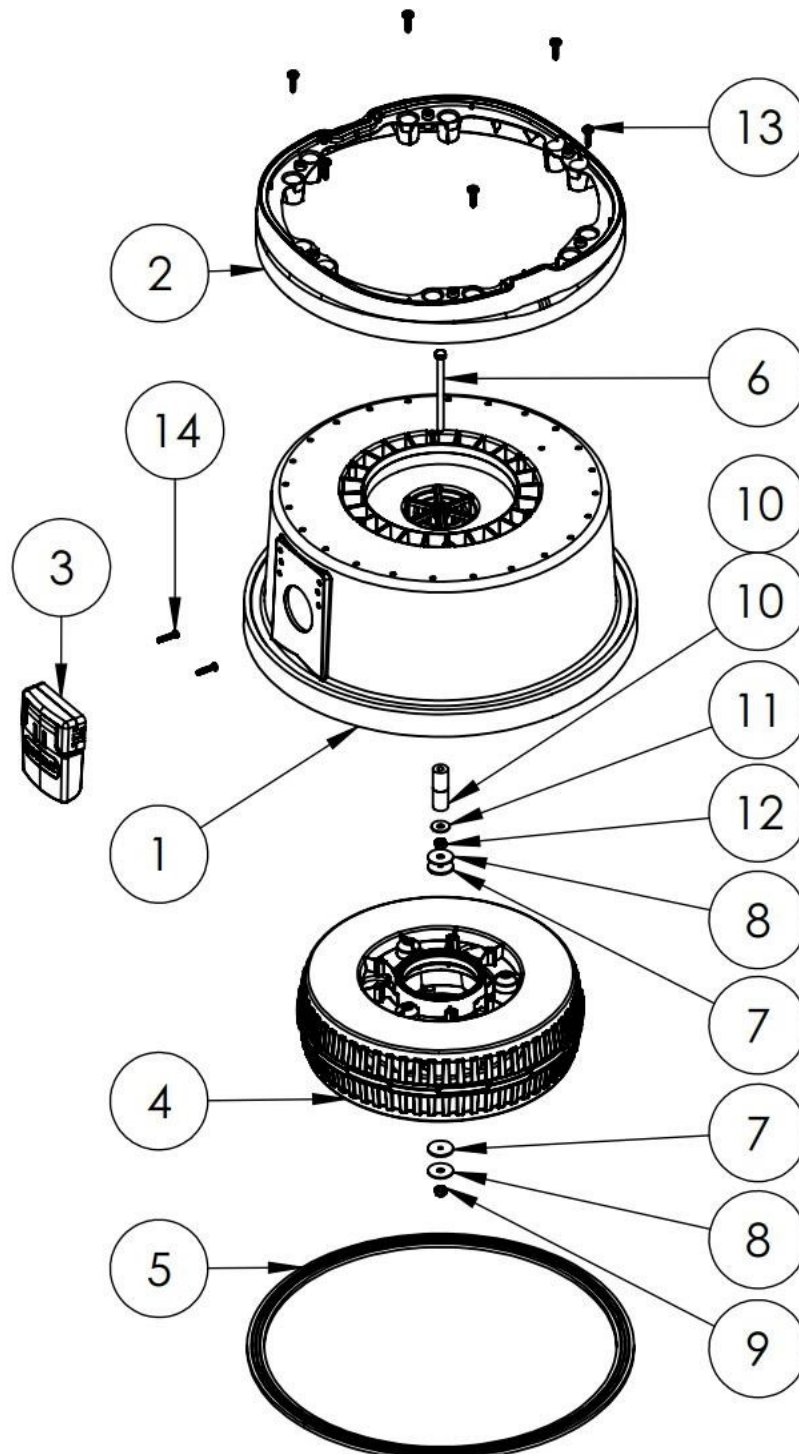

E - Behälter

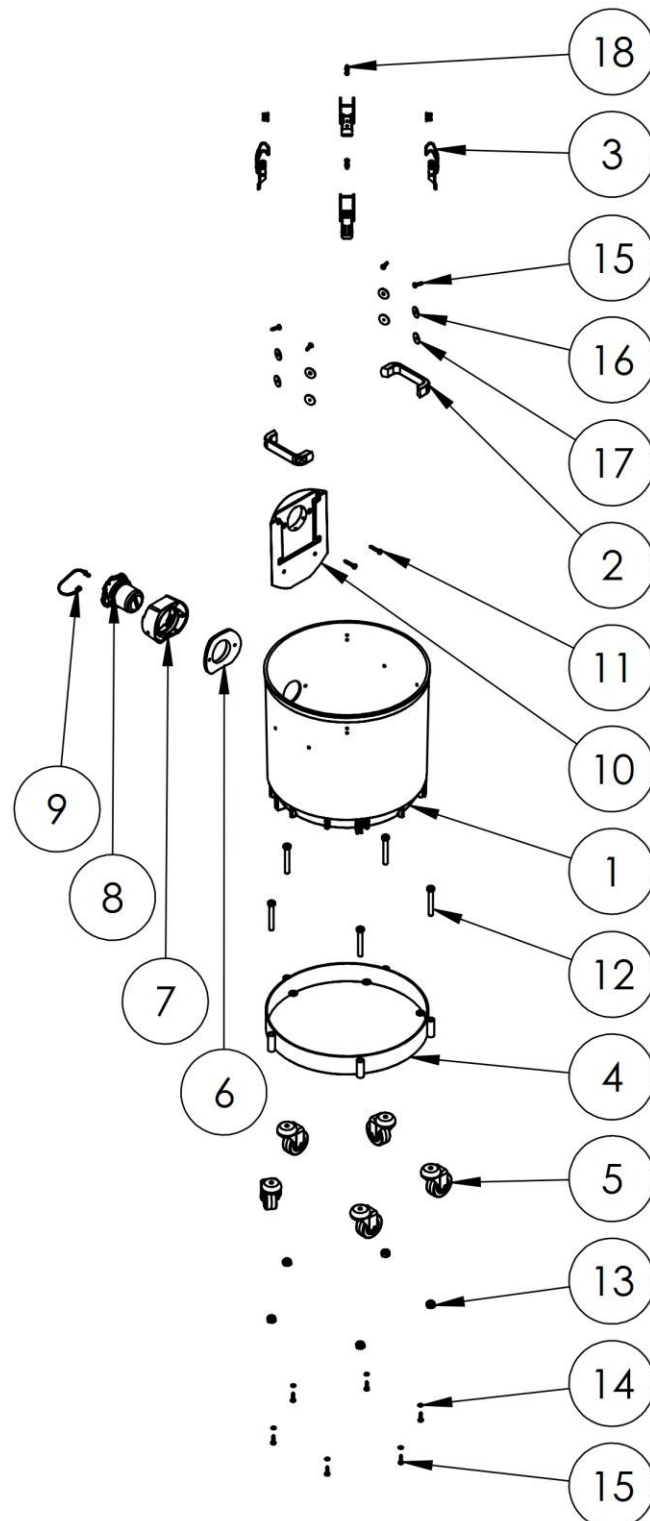

Schleifstaubsauger JANVAC 1600-H POWER

Artikelnr.: 115 095 200

Seite 7 von 9 / 10-2021

 06.04.2022/sai

Pos.	Benennung1	Description	Hersteller-ID	Artikelnr
A- Baugruppen				
A-01	Behälter	Container Assembly	siehe Abbildung - E	
A-02	Kanalfilter	Tube filter	84.67.1111	115095008
A-03	Adapterring	Adapting ring	siehe Abbildung -D	
A-04	Dichtung	Gasket	81.95.0015	
A-05	Pumpeneinheit	Pump unit	Siehe Abbildung-C	
A-06	Schraube TCC 5x16 SP	Screw TCC 5x16 SP	81.97.0140	115095214
A-07	Motorkopf	Motor top	Siehe Abbildung -B	
A-08	Dichtung	Gasket	81.95.3770	115094377
A-09	Graue Zylinderkopffhaube	Grey Cap for cylinder	81.89.3640	115095005
A-10	Nachrüstsatz Kabelaufwickler	Cable re-winder retrofit kit	81.99.0005	115095460
B- Motorkopf				
B-01	Motoroberteil	Motor top blue	81.89.3653	
B-02	Schaltergehäuse	Switch housing	81.89.3760	115095376
B-03	Ein- u. Aus Schalter f. Janvac 1600- H	On-Off Switch f. Janvac 1600-H	85.75.4560	115095031
B-04	Schalter für Automatik	Switch for automatic	81.75.0110	115095414
B-05	Steckdose 230V (Lasteingang)	Socket Schuco	81.75.4120	115095412
B-06	Gummischeibe 6 x 26	Rubber disc 6 x 26	81.95.4870	115095024
B-07	Montagebeschlag	Mounting bracket	81.89.4880	115096028
B-08	Schaum	Foam	81.93.0002	
B-09	Zuleitungskabel	Cable	81.75.0010	115095094
B-10	Zugentlastung	Relief bracket	81.75.0060	115095111
B-11	Kabeldurchführung	Line entrance	81.75.0080	115095080
B-12	Lüsterklemme	Supply terminal	81.75.0041	
B-13	Schraube	Screw	83.97.0023	
B-14	Schraube TCC 2,9 x 19 mm	Screw TCC 2,9 x 19 mm	81.97.0030	115095703
B-15	Schraube 4,2 x 19	Screw 4,2 x 19	83.97.4110	115095411
B-16	Kabeleinheit	Wiring collection	81.75.1019	
B-17	Schraube TCC 5x16 SP	Screw TCC 5x16 SP	81.97.0140	115095214
C- Pumpeneinheit				
C-01	Basis	Lower part	81.89.1004	115095467
C-02	Motordichtung	Motor gasket	81.95.0033	
C-03	Motor	Motor	84.72.0112	115095206
C-04	Sperring	Locking ring	81.97.2450	
C-05	Motordichtung	Motor gasket	81.95.8970	
C-06	Kabeleinheit	Wiring collection	81.75.1007	
C-07	Lufführung Kegel	Air guide cone	81.89.1003	115095468
C-08	Schalldämpferschaum	Muffling Foam	81.93.1006	115095469
C-09	Oberteil	Top part	81.89.1002	115095416
C-10	Schlauch	Hoses	84.54.0011	115095403
C-11	Piepsereinheit	Beeper	81.75.0062	115095413
C-12	Druckschalter	Pressure switch	81.75.0073	115095272
C-13	Kabel blau	Wire blue	81.75.1021	
C-14	Kabel rot	Wire red	81.75.1020	

Schleifstaubsauger JANVAC 1600-H POWER

Maschinen, Geräte, Fachwerkzeuge für
Raumausstatter, Fußbodenleger und
den Fußbodenbelagshandel

Artikelnr.: 115 095 200

Seite 8 von 9 / 10-2021

 06.04.2022/sai

Pos.	Benennung1	Description	Hersteller-ID	Artikelnr
C-15	Elektronik	Electronics	81.75.0666	
C-16	Schraube TCC 5x16 SP	Screw TCC 5x16 SP	81.97.0140	115095214
C-17	Leitung	Wires	81.75.1022	

D- Adapterring

D-01	Adapterring	Adaptor ring	83.89.424W	115095209
D-02	Luftleiterring, grau	Exhaust air ring, grey	83.89.4251	115095207
D-03	Filterreinigungsventil	Filter cleaning valve	83.89.492C	115095036
D-04	Hepa Filter	Hepa Filter	84.67.5036	115095225
D-05	Dichtung	Gasket	81.95.3390	115095016
D-06	Bolzen für Filter	Spacer	83.97.421H	
D-07	Dichtung	Gasket	81.95.0015	
D-08	Scheibe	Washer	81.97.1000	
D-09	Selbstsichernde Mutter	Nut	83.97.050A	115095023
D-10	Stützsteg	Distance piece	83.97.4661	
D-11	Scheibe	Washer	81.97.0008	
D-12	Mutter M6	Nut M6	81.97.0500	
D-13	Schraube TCC 5x16 SP	Screw TCC 5x16 SP	81.97.0140	115095214
D-14	Schraube	Screw	81.97.1530	115095402

E- Behälter

E-01	Aufsammelbehälter	Collection container	83.77.5139	115095520
E-02	Handgriff	Handle	81.91.098A	115095098
E-03	Behälterklammer	Container clips	81.91.342A	115095022
E-04	Fahrgestell D-364 Metall	Wheel base	83.85.5140	115095514
E-05	Rad/ Metallausführung	Wheel	81.87.3821	115095603
E-06	Gummidichtung für Bajonett-Kupplung	Rubbrt seal for bayonet coupling	81.95.0038	115095426
E-07	Gehäuse für Bajonett-Kupplung	Housing for bayonet coupling	81.56.3840	115097762
E-08	Stopfen für Bajonett-Kupplung	Bayonet plug	81.89.3800	115095222
E-09	Kabelbinder	Cable-ties	84.67.0006	115095218
E-10	Beutelhalter für Bajonett	Bag slide holder	83.89.3800	115095219
E-11	Schraube	Screw	81.97.3950	115095221
E-12	Schraube M10x70 DIN912 Galv.verz.	Screw M10x70 DIN912 Galv.verz	00841070	004010070
E-13	Mutter M10	Nut M10	83.97.5178	115095063
E-14	Scheibe	Disc	81.97.0772	115095078
E-15	Schraube TCC 5 x 16 SP	Screw TCC 5 x 16 SP	81.97.0140	115095214
E-16	Scheibe	Disc	81.97.1001	
E-17	Gummischeibe	Rubber washer	81.97.099A	
E-18	Niete	Rivet	81.97.0430	
E-19	Vlies-Filterbeutel	Felt filter	84.64.0553	115095260

Schleifstaubsauger JANVAC 1600-H POWER

Artikelnr.: 115 095 200

Seite 9 von 9 / 10-2021

06.04.2022/sai

STANDARDZUBEHÖR / standard accessories



1.	Saugschlauch 5m, antistatisch schwarz/grau mit neuer Bajonettkupplung und flexiblem Anschlussstutzen	Suction hose 5m, antistatic black/grey with new bayonet coupling and flexible connection piece	115 095 270
1.1	Bajonettkupplung	Bayonet coupling	115 095 427
1.2	Endstutzen konisch weich	Suction port	115 095 018
1.3	Saugschlauch Ø 38 antistatisch schwarz/grau, (Meterware)	Suction hose Ø 38 antistatic black/grey, (per m)	115 095 880
2.	fahrbare Bodensaugdüse - 45cm	Floor suction nozzle - 45cm	115 030 005
3.	Fugendüse	Groove nozzle	785 000 021
4.	Saugrohr 3-teilig	Suction tube - 3 parts	115 095 102
5.	Adapter	Adapter	115 030 200
6.	Bypass Ventil inkl. 2 Stutzen	Pressure Compensation Valve	115 095 215
	Auffangbeutel synthetisch (o.Abb)	Collection bag synthetic (not shown)	115 095 260
	Plastiksack	Plastic bag	115 095 290

Sonderzubehör optional

Antistatik Nachrüstsatz

Antistatic retrofit kit

115 095 230